

SST-20-WH Gen 2

High Power White LEDs

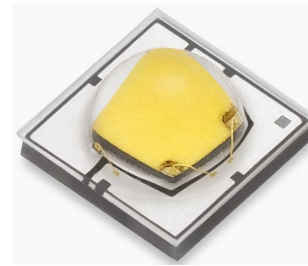

Features

- High CRI, high-efficacy warm white LEDs for high-performance directional lighting applications.
- The vertical chip delivers high lumen density and small emitting angle, ideal for maximizing the intensity and beam distance in directional lighting.
- The phosphor-on-chip technology features high color uniformity over radiation angle, enabling superior light quality for beam spots.
- LM-80 10,000-hr test data available, excellent TM-21 lifetime and color stability
- Maximum Drive Current: 2 A
- Color Temperature: 2700K, 3000K, 3500K, 4000K
- Color Rendering Index: > 95
- Low thermal resistance: 1.6 °C/W
- ANSI-compatible chromaticity bins
- Available in 2 soldering footprint configurations
- Electrically isolated thermal path
- 8 kV HBM ESD rating per ANSI/ESDA/JEDEC JS-001



Applications

- Wall Washer
- Track Light
- Spotlight
- Task Light
- Miniature Recessed Lights
- Landscape Lighting
- Portable Lighting
- Stage & Studio Lighting

Table of Contents

Ordering Information.....	2
Binning Structure.....	4
Absolute Maximum Ratings.....	8
Product Characteristics.....	8
Soldering Profile.....	11
Mechanical Dimensions.....	12
Tape and Reel Outline.....	14
Shipping Label.....	15
Packaging.....	16
Notes.....	17



Ordering Information

Ordering Part Numbers¹

CRI	CCT	Luminous Flux		Chromaticity Bin Kit ³	Solder Pad Type ⁴	Ordering Part Number
		Minimum Flux Bin ¹	Minimum Flux ²			
> 95	2700K	B3	107 lm	271	A	SST-20-WH27-A2-B3271
					B	SST-20-WH27-B2-B3271
				272	A	SST-20-WH27-A2-B3272
					B	SST-20-WH27-B2-B3272
		B4	114 lm	271	A	SST-20-WH27-A2-B4271
					B	SST-20-WH27-B2-B4271
				272	A	SST-20-WH27-A2-B4272
					B	SST-20-WH27-B2-B4272
	3000K	B4	114 lm	301	A	SST-20-WH30-A2-B4301
					B	SST-20-WH30-B2-B4301
				302	A	SST-20-WH30-A2-B4302
					B	SST-20-WH30-B2-B4302
		B5	121 lm	301	A	SST-20-WH30-A2-B5301
					B	SST-20-WH30-B2-B5301
				302	A	SST-20-WH30-A2-B5302
					B	SST-20-WH30-B2-B5302
	3500K	B5	121 lm	351	A	SST-20-WH35-A2-B5351
					B	SST-20-WH35-B2-B5351
				352	A	SST-20-WH35-A2-B5352
					B	SST-20-WH35-B2-B5352
		B6	128 lm	351	A	SST-20-WH35-A2-B6351
					B	SST-20-WH35-B2-B6351
				352	A	SST-20-WH35-A2-B6352
					B	SST-20-WH35-B2-B6352
4000K	B6	128 lm	401	A	SST-20-WH40-A2-B6401	
				B	SST-20-WH40-B2-B6401	
			402	A	SST-20-WH40-A2-B6402	
				B	SST-20-WH40-B2-B6402	
	B7	135 lm	401	A	SST-20-WH40-A2-B7401	
				B	SST-20-WH40-B2-B7401	
			402	A	SST-20-WH40-A2-B7402	
				B	SST-20-WH40-B2-B7402	



Ordering Information

Part Number Nomenclature

SST

20

W<xyy>

<p#>

<ffccc>

Product Family	Chip Area	Color	Package Configuration	Bin Kit
S: Surface Mount S: Dome Lensed T: Single Emitter	20: 2.0 mm ²	W: White <x> CRI Category Code H: CRI>95 <yy> Color Temperature 27: 2700K 40: 4000K	<p> Solder Pad Configuration A: type A - see page 12 B: type B - see page 13 <#> Chip Generation 2: Gen 2	<ff> Minimum Flux Bin, see 'Luminus Flux Binning' table for details <ccc> Chromaticity Bin Kit, see 'Chromaticity Bin Kit Codes' table for details

Note:

1. The Ordering Part Number specifies the Minimum Flux Bin in shipment; higher flux bins may be shipped without advance notice. Please refer to 'Luminous Flux Binning' table for details of all flux bins.
2. Product test condition: $I_f=350$ mA, $T_j=85^\circ$ C.
3. Shipments always adhere to the color bins specified in each Chromaticity Bin Kit. See 'Chromaticity Bin Kit Codes' table for the color bins included in each Bin Kit.
4. See 'Mechanical Dimensions' for A and B types' solder pad configurations. All product mechanical, electrical and optical specifications are otherwise identical.



Binning Structure

Luminous Flux Binning^{1,2}

Flux Bin Code	Binning @ 350 mA			Correlated Minimum Flux (lm) @ $T_j=85^\circ\text{C}^2$			
	$T_j = 85^\circ\text{C}^1$		$T_j = 25^\circ\text{C}$				
	Minimum Flux (lm)	Maximum Flux (lm)	Minimum Flux (lm)	700 mA	1000 mA	1500 mA	2000 mA
B2	100	107	110	185	251	350	437
B3	107	114	118	198	269	375	468
B4	114	121	125	211	286	399	498
B5	121	128	133	224	304	424	529
B6	128	135	141	237	321	448	559
B7	135	142	149	250	339	473	590
B8	142	152	156	263	356	497	621
B9	152	162	167	281	382	532	664

Forward Voltage Binning³

Voltage Bin Code ³	Binning @ 350 mA, $T_j = 85^\circ\text{C}$	
	Minimum Voltage (V)	Maximum Voltage (V)
VH	2.5	2.7
VJ	2.7	2.9

Note:

- LEDs are measured at 25°C ambient temperature with 350 mA 20 ms single pulse. The measured values are correlated to values at 85°C junction temperature (T_j). Luminus maintains a $\pm 6\%$ tolerance on flux measurement.
- Flux values at other junction temperature (T_j) and/or forward current conditions are calculated and for reference only.
- Individual voltage bins are not orderable.



Binning Structure

Chromaticity Binning Coordinates

CCT	Bin Code	CIE _x	CIE _y	Bin Code	CIE _x	CIE _y	Bin Code	CIE _x	CIE _y	Bin Code	CIE _x	CIE _y
2700K	JA1	0.4373	0.3893	JA2	0.4418	0.3981	JA3	0.4475	0.3994	JA4	0.4428	0.3906
		0.4418	0.3981		0.4465	0.4071		0.4523	0.4085		0.4475	0.3994
		0.4475	0.3994		0.4523	0.4085		0.4582	0.4099		0.4532	0.4008
		0.4428	0.3906		0.4475	0.3994		0.4532	0.4008		0.4483	0.3919
	JB1	0.4465	0.4071	JB2	0.4513	0.4164	JB3	0.4573	0.4178	JB4	0.4523	0.4085
		0.4513	0.4164		0.4562	0.4260		0.4624	0.4274		0.4573	0.4178
		0.4573	0.4178		0.4624	0.4274		0.4687	0.4289		0.4634	0.4193
		0.4523	0.4085		0.4573	0.4178		0.4634	0.4193		0.4582	0.4099
	JC1	0.4582	0.4099	JC2	0.4634	0.4193	JC3	0.4695	0.4207	JC4	0.4641	0.4112
		0.4634	0.4193		0.4687	0.4289		0.4750	0.4304		0.4695	0.4207
		0.4695	0.4207		0.4750	0.4304		0.4813	0.4319		0.4756	0.4221
		0.4641	0.4112		0.4695	0.4207		0.4756	0.4221		0.4700	0.4126
	JD1	0.4483	0.3919	JD2	0.4532	0.4008	JD3	0.4589	0.4021	JD4	0.4538	0.3931
		0.4532	0.4008		0.4582	0.4099		0.4641	0.4112		0.4589	0.4021
		0.4589	0.4021		0.4641	0.4112		0.4700	0.4126		0.4646	0.4034
		0.4538	0.3931		0.4589	0.4021		0.4646	0.4034		0.4593	0.3944
3000K	HA1	0.4147	0.3814	HA2	0.4183	0.3898	HA3	0.4242	0.3919	HA4	0.4203	0.3833
		0.4183	0.3898		0.4221	0.3984		0.4281	0.4006		0.4242	0.3919
		0.4242	0.3919		0.4281	0.3919		0.4342	0.4028		0.4300	0.3939
		0.4203	0.3833		0.4242	0.4073		0.4300	0.3939		0.4259	0.3853
	HB1	0.4221	0.3984	HB2	0.4259	0.4006	HB3	0.4322	0.4096	HB4	0.4281	0.4006
		0.4259	0.4073		0.4299	0.4165		0.4364	0.4188		0.4322	0.4096
		0.4322	0.4096		0.4364	0.4188		0.4430	0.4212		0.4385	0.4119
		0.4281	0.4028		0.4322	0.4096		0.4385	0.4119		0.4342	0.4028
	HC1	0.4342	0.4119	HC2	0.4385	0.4119	HC3	0.4449	0.4141	HC4	0.4403	0.4049
		0.4385	0.4141		0.4430	0.4212		0.4496	0.4236		0.4449	0.4141
		0.4449	0.4049		0.4496	0.4236		0.4562	0.4260		0.4513	0.4164
		0.4403	0.3853		0.4449	0.4141		0.4513	0.4164		0.4465	0.4071
	HD1	0.4259	0.3939	HD2	0.4300	0.3939	HD3	0.4359	0.3960	HD4	0.4316	0.3873
		0.4300	0.3960		0.4342	0.4028		0.4403	0.4049		0.4359	0.3960
		0.4359	0.3873		0.4403	0.4049		0.4465	0.4071		0.4418	0.3981
		0.4316	0.4006		0.4359	0.3960		0.4418	0.3981		0.4373	0.3893



Binning Structure

Chromaticity Binning Coordinates

CCT	Bin Code	CIE _x	CIE _y	Bin Code	CIE _x	CIE _y	Bin Code	CIE _x	CIE _y	Bin Code	CIE _x	CIE _y	
3500K	GA1	0.3889	0.3690	GA2	0.3915	0.3768	GA3	0.3981	0.3800	GA4	0.3953	0.3720	
		0.3915	0.3768		0.3941	0.3848		0.4010	0.3882		0.3981	0.3800	
		0.3981	0.3800		0.4010	0.3882		0.4080	0.3916		0.4048	0.3832	
		0.3953	0.3720		0.3981	0.3800		0.4048	0.3832		0.4017	0.3751	
	GB1	0.3941	0.3848	GB2	0.3968	0.3930	GB3	0.4040	0.3966	GB4	0.4010	0.3882	
		0.3968	0.3930		0.3996	0.4015		0.4071	0.4052		0.4040	0.3966	
		0.4040	0.3966		0.4071	0.4052		0.4146	0.4089		0.4113	0.4001	
		0.4010	0.3882		0.4040	0.3966		0.4113	0.4001		0.4080	0.3916	
	GC1	0.4080	0.3916	GC2	0.4113	0.4001	GC3	0.4186	0.4037	GC4	0.4150	0.3950	
		0.4113	0.4001		0.4146	0.4089		0.4222	0.4127		0.4186	0.4037	
		0.4186	0.4037		0.4222	0.4127		0.4299	0.4165		0.4259	0.4073	
		0.4150	0.3950		0.4186	0.4037		0.4259	0.4073		0.4221	0.3984	
	GD1	0.4017	0.3751	GD2	0.4048	0.3832	GD3	0.4116	0.3865	GD4	0.4082	0.3782	
		0.4048	0.3832		0.4080	0.3916		0.4150	0.3950		0.4116	0.3865	
		0.4116	0.3865		0.4150	0.3950		0.4221	0.3984		0.4183	0.3898	
		0.4082	0.3782		0.4116	0.3865		0.4183	0.3898		0.4147	0.3814	
	4000K	FA1	0.3670	0.3578	FA2	0.3686	0.3649	FA3	0.3744	0.3685	FA4	0.3726	0.3612
			0.3686	0.3649		0.3702	0.3722		0.3763	0.3760		0.3744	0.3685
			0.3744	0.3685		0.3763	0.3760		0.3825	0.3798		0.3804	0.3721
			0.3726	0.3612		0.3744	0.3685		0.3804	0.3721		0.3783	0.3646
FB1		0.3702	0.3722	FB2	0.3719	0.3797	FB3	0.3782	0.3837	FB4	0.3763	0.3760	
		0.3719	0.3797		0.3736	0.3874		0.3802	0.3916		0.3782	0.3837	
		0.3782	0.3837		0.3802	0.3916		0.3869	0.3958		0.3847	0.3877	
		0.3763	0.3760		0.3782	0.3837		0.3847	0.3877		0.3825	0.3798	
FC1		0.3825	0.3798	FC2	0.3847	0.3877	FC3	0.3912	0.3917	FC4	0.3887	0.3836	
		0.3847	0.3877		0.3869	0.3958		0.3937	0.4001		0.3912	0.3917	
		0.3912	0.3917		0.3937	0.4001		0.4006	0.4044		0.3978	0.3958	
		0.3887	0.3836		0.3912	0.3917		0.3978	0.3958		0.3950	0.3875	
FD1		0.3783	0.3646	FD2	0.3804	0.3721	FD3	0.3863	0.3758	FD4	0.3840	0.3681	
		0.3804	0.3721		0.3825	0.3798		0.3887	0.3836		0.3863	0.3758	
		0.3863	0.3758		0.3887	0.3836		0.3950	0.3875		0.3924	0.3794	
		0.3840	0.3681		0.3863	0.3758		0.3924	0.3794		0.3898	0.3716	



Binning Structure

Chromaticity Binning Diagram^{1,2}

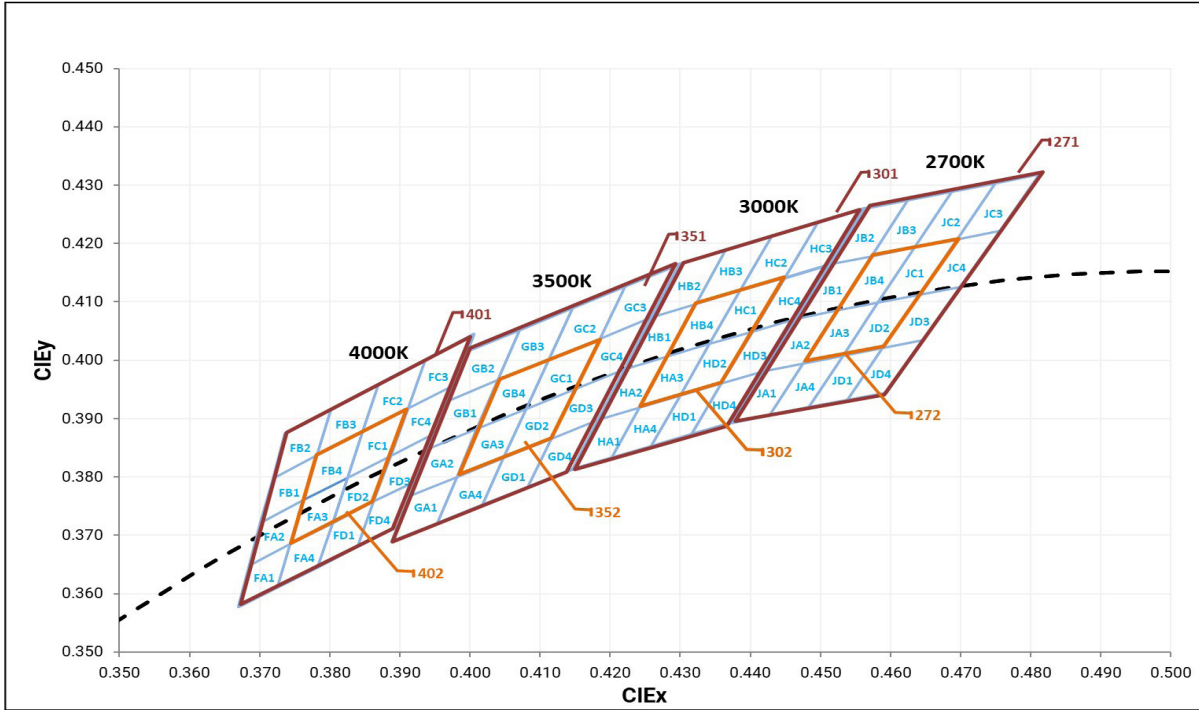

Chromaticity Bin Kit Codes

CCT	Bin Kit	Chromaticity Bins
2700K	271	JA1, JA2, JA3, JA4, JB1, JB2, JB3, JB4, JC1, JC2, JC3, JC4, JD1, JD2, JD3, JD4
	272	JA3, JB4, JC1, JD2
3000K	301	HA1, HA2, HA3, HA4, HB1, HB2, HB3, HB4, HC1, HC2, HC3, HC4, HD1, HD2, HD3, HD4
	302	HA3, HB4, HC1, HD2
3500K	351	GA1, GA2, GA3, GA4, GB1, GB2, GB3, GB4, GC1, GC2, GC3, GC4, GD1, GD2, GD3, GD4
	352	GA3, GB4, GC1, GD2
4000K	401	FA1, FA2, FA3, FA4, FB1, FB2, FB3, FB4, FC1, FC2, FC3, FC4, FD1, FD2, FD3, FD4
	402	FA3, FB4, FC1, FD2

Note:

- LED chromaticity is measured and binned at 25°C ambient temperature with 350 mA 20 ms single pulse.
- Luminus maintains a tolerance of ± 0.005 on Chromaticity (CIE_x, CIE_y) measurement.



Absolute Maximum Ratings

		Symbol	Values	Unit
DC Forward Current	Minimum	$I_{f\ min}$	0.2	A
	Maximum	$I_{f\ max}$	2.0	
Surge Current (t<10 ms, Duty Cycle < 10%)		$I_{s\ max}$	3.0	A
Reverse Voltage (@ $I_f = 10\ mA$)		V_r	5	V
Power Dissipation		P_D	7	W
Junction Temperature		$T_{j\ max}$	150	°C
Operating Temperature		T_{opr}	-40 to 100	°C
Storage Temperature		T_{stg}	-40 to 100	°C
ESD withstand Voltage HBM Per ANSI/ESDA/JEDEC JS-001		V_{HBM}	8	kV
ESD withstand Voltage CDM Per ANSI/ESDA/JEDEC JS-002		V_{CDM}	1	kV

Product Characteristics

Parameter		Symbol	Value	Unit
Color Rendering Index ¹ ($T_j = 85^\circ\text{C}$)		CRI	> 95	
Color Rendering, R9 ($T_j = 85^\circ\text{C}$)		R9	> 50	
Viewing Angle (FWHM)		$2\theta_{1/2}$	120	°
Forward Voltage ($I_f = 350\ mA$, $T_j = 85^\circ\text{C}$)	Minimum	$V_{f\ min}$	2.5	V
	Typical	$V_{f\ typ}$	2.7	
	Maximum	$V_{f\ max}$	2.9	
Temperature Coefficient of Voltage		$\partial V_f / \partial T$	-1.15	mV/°C
Thermal Resistance (Electrical) Junction/Solder Point		$R_{thjs-EL}$	1.6	°C/W

Note:

1. Luminus maintains a tolerance of ± 2 on Color Rendering Index (CRI) measurement.



Relative Luminous Flux

Forward Current: $\phi_v/\phi_v(0.35\text{ A}), T_j = 85^\circ\text{C}$

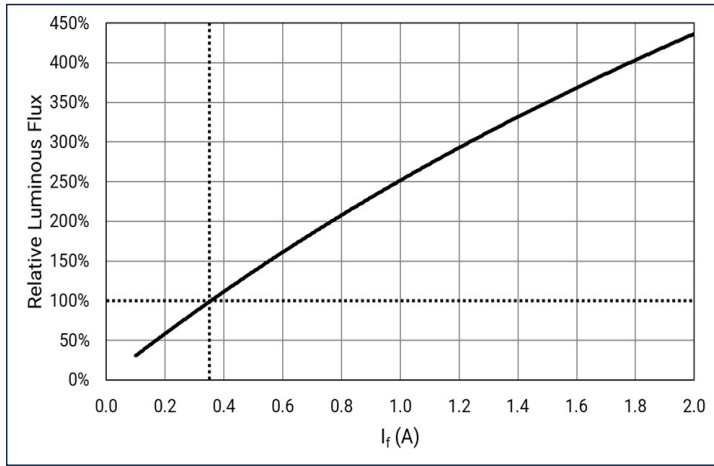

Temperature (T_j): $\phi_v/\phi_v(85^\circ\text{C}), I_f = 0.35\text{ A}$

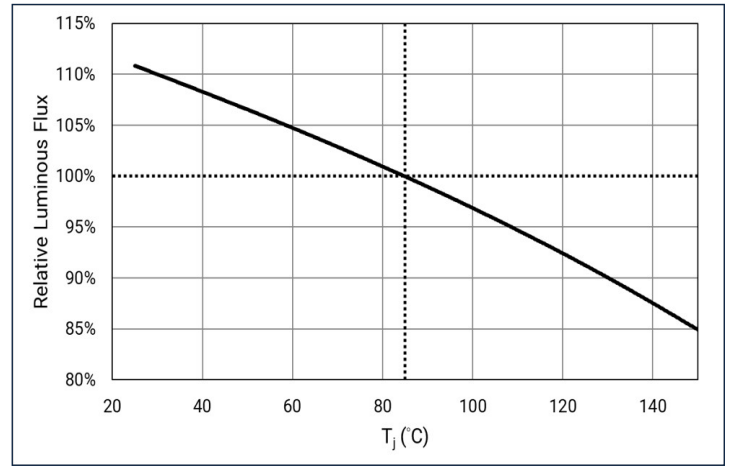

Forward Voltage

Forward Current: $\Delta V_f = V_f(I_f) - V_f(0.35\text{ A}), T_j = 85^\circ\text{C}$

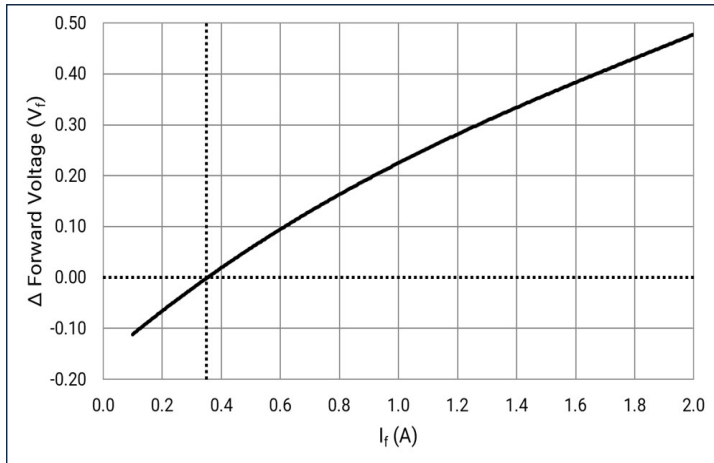

Temperature (T_j): $\Delta V_f = V_f(T_j) - V_f(85^\circ\text{C}), I_f = 0.35\text{ A}$

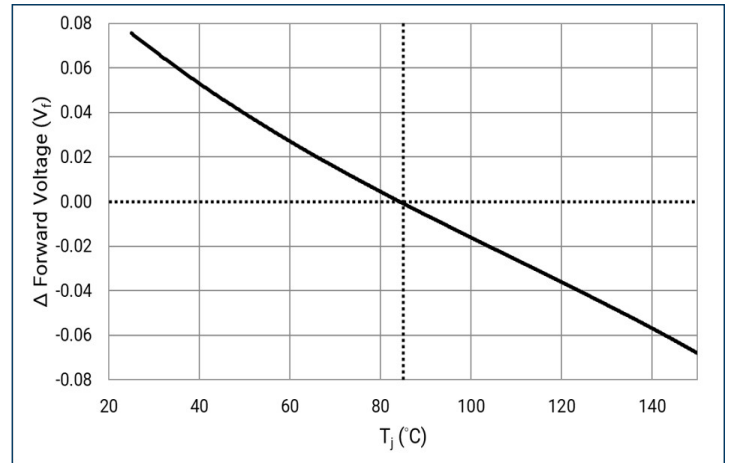

Relative Chromaticity

Forward Current: $\Delta \text{CIEx,y} = \text{CIEx,y}(I_f) - \text{CIEx,y}(0.35\text{ A}), T_j = 85^\circ\text{C}$

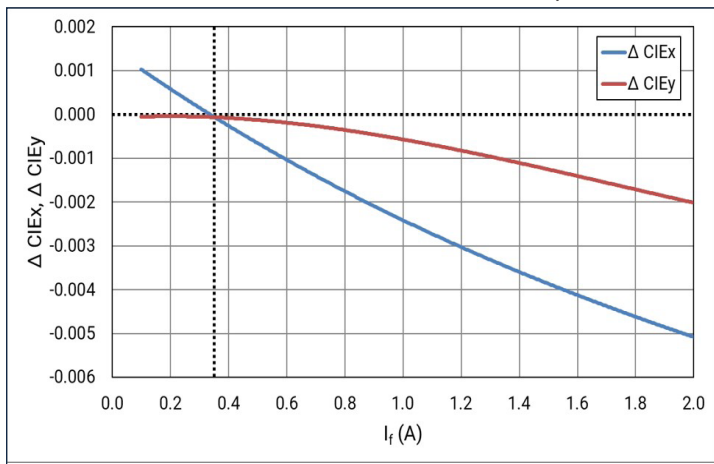

Temperature (T_j): $\Delta \text{CIEx,y} = \text{CIEx,y}(T_j) - \text{CIEx,y}(25^\circ\text{C}), I_f = 0.35\text{ A}$

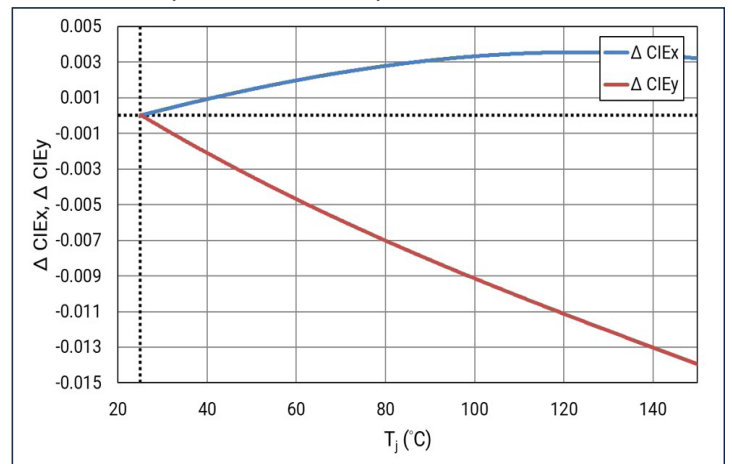



Angular Distribution

$I_f = 0.35 \text{ A}; T_j = 25^\circ\text{C}$

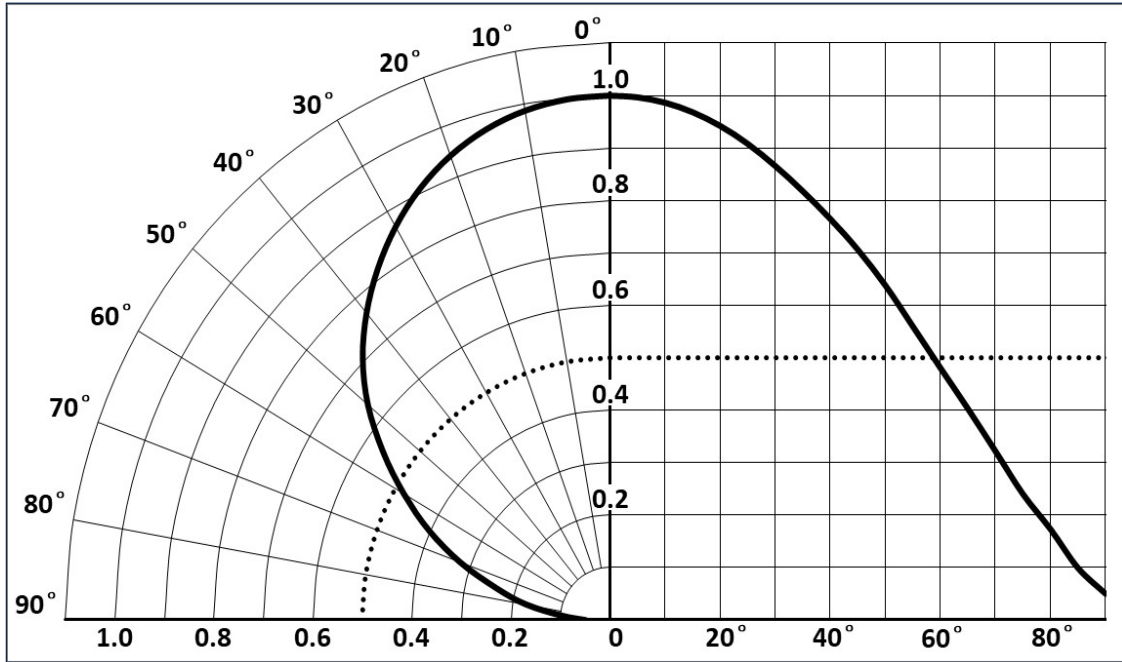

Relative Spectral Power Distribution

$I_f = 0.35 \text{ A}; T_j = 85^\circ\text{C}$

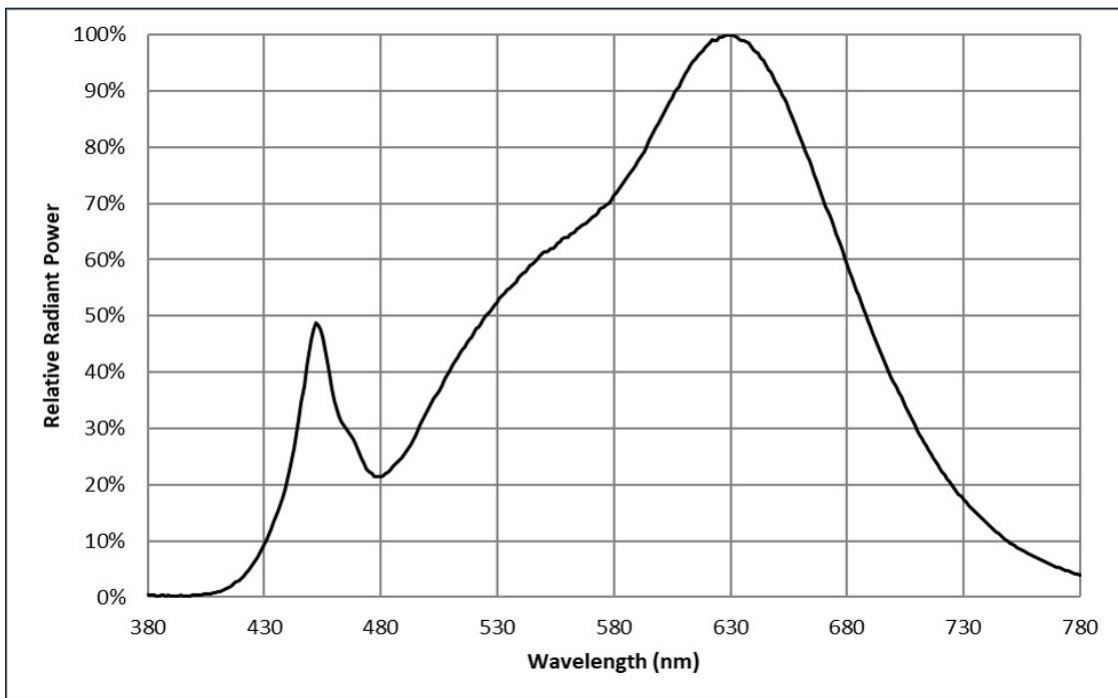



Soldering Profile

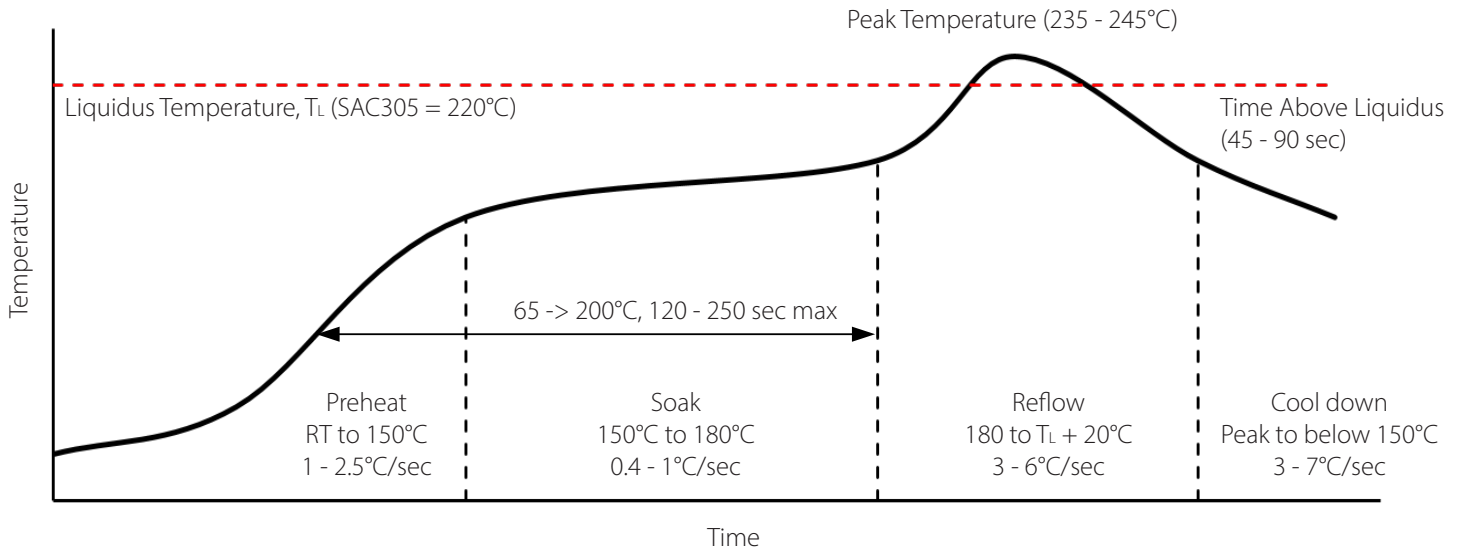

SMT Rework Guideline	Manual Hotplate Reflow	Hot Air Gun Reflow
Heating Time	< 60 sec	
Hotplate Temperature	< 245°C	< 150°C

Note:

- Product complies to Moisture Sensitivity Level 3 (MSL 3).
- The numbers in the table are specific to SAC305. Luminus recommends using an SAC305 solder paste with a no-clean flux for RoHS compliant products.
- During the pick and place process, axial forces on the dome (or window) should not exceed 0.5 Newtons (N).
- Use of a multi-zone IR reflow oven with a nitrogen blanket is recommended.
- Time-temperature profile of the reflow process showing the four functional profile zones are defined in IPC-7801. Temperature is referenced to the center of the PCB.
- Luminus recommends to use the solder paste data sheet information as a starting point in time-temperature process development.
- These are general guidelines. Consult the solder paste manufacturer's datasheet for guidelines specific to the alloy and flux combination used in your application.
For more information, please refer to:
<https://luminusdevices.zendesk.com/hc/en-us/articles/360060306692-How-do-I-Reflow-Solder-Luminus-SMD-Components->
- For any technical questions about soldering process, please contact Luminus at techsupport@luminus.com.



Mechanical Dimensions - Type A Solder Pad¹

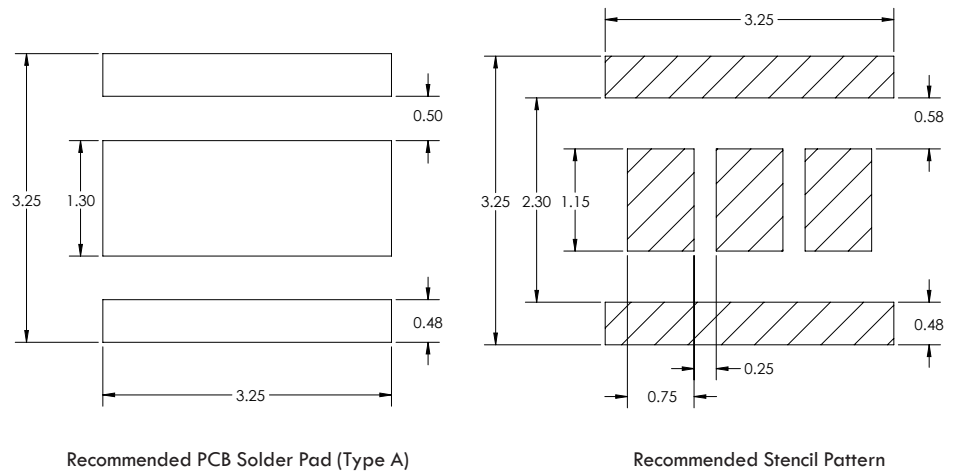
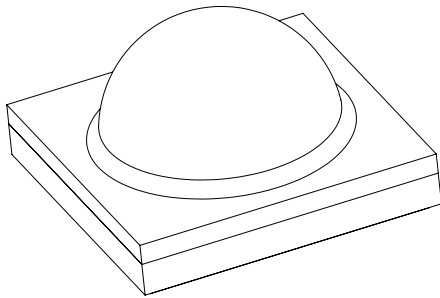
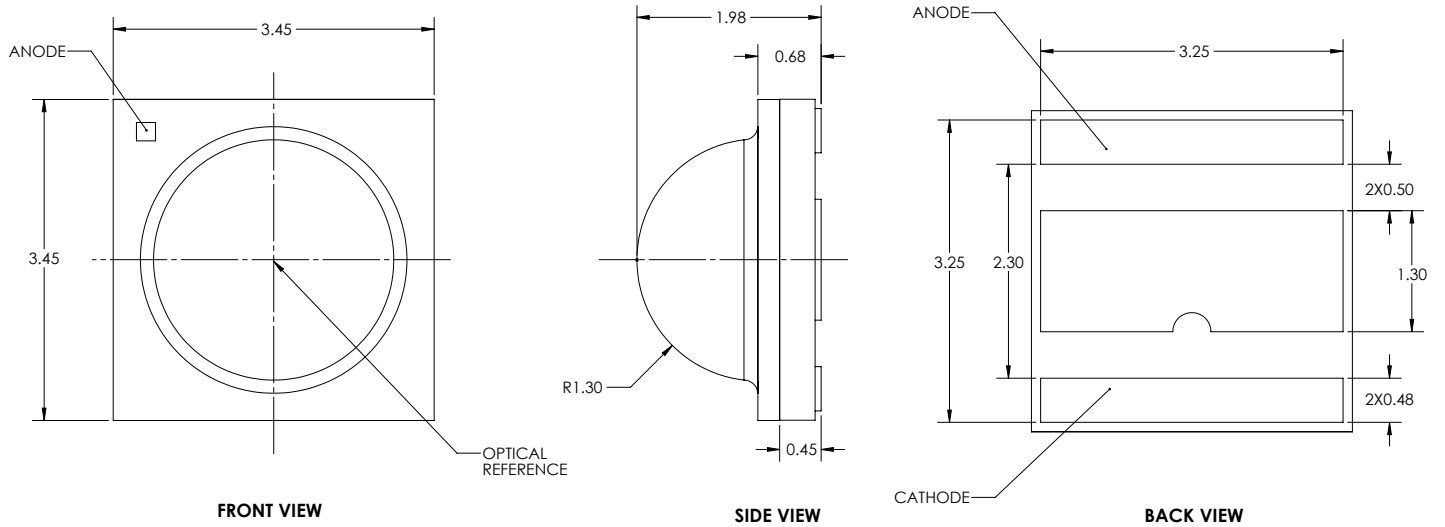

Note:

1. All dimensions are in millimeter ± 0.13 mm.



Mechanical Dimensions - Type B Solder Pad¹

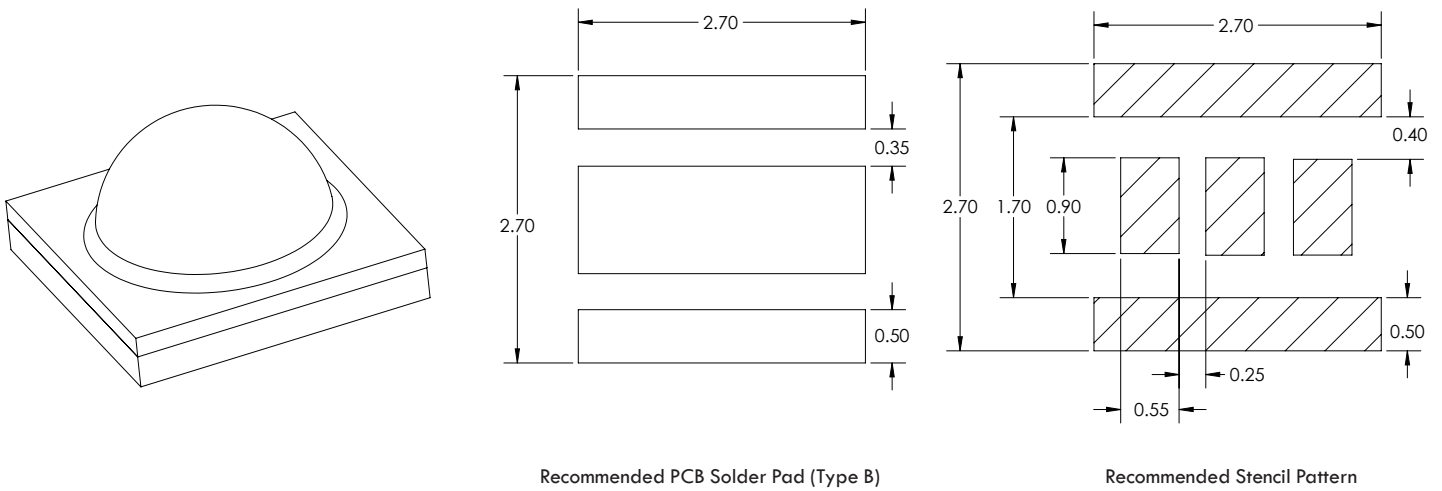
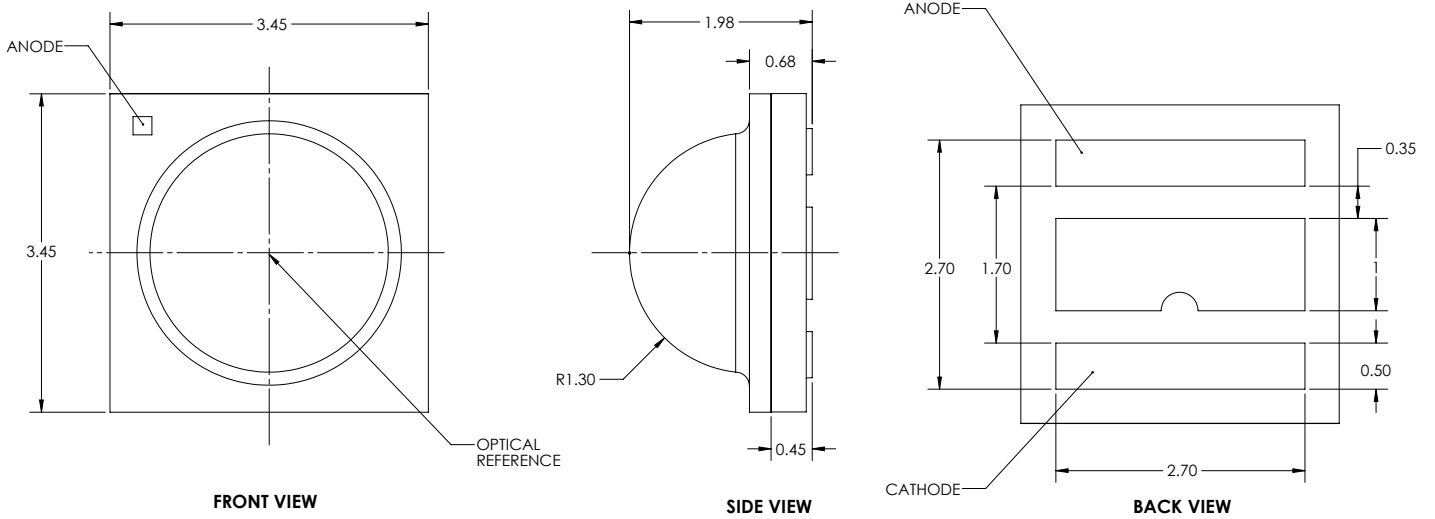

Note:

1. All dimensions are in millimeter ± 0.13 mm.



Tape and Reel Outline

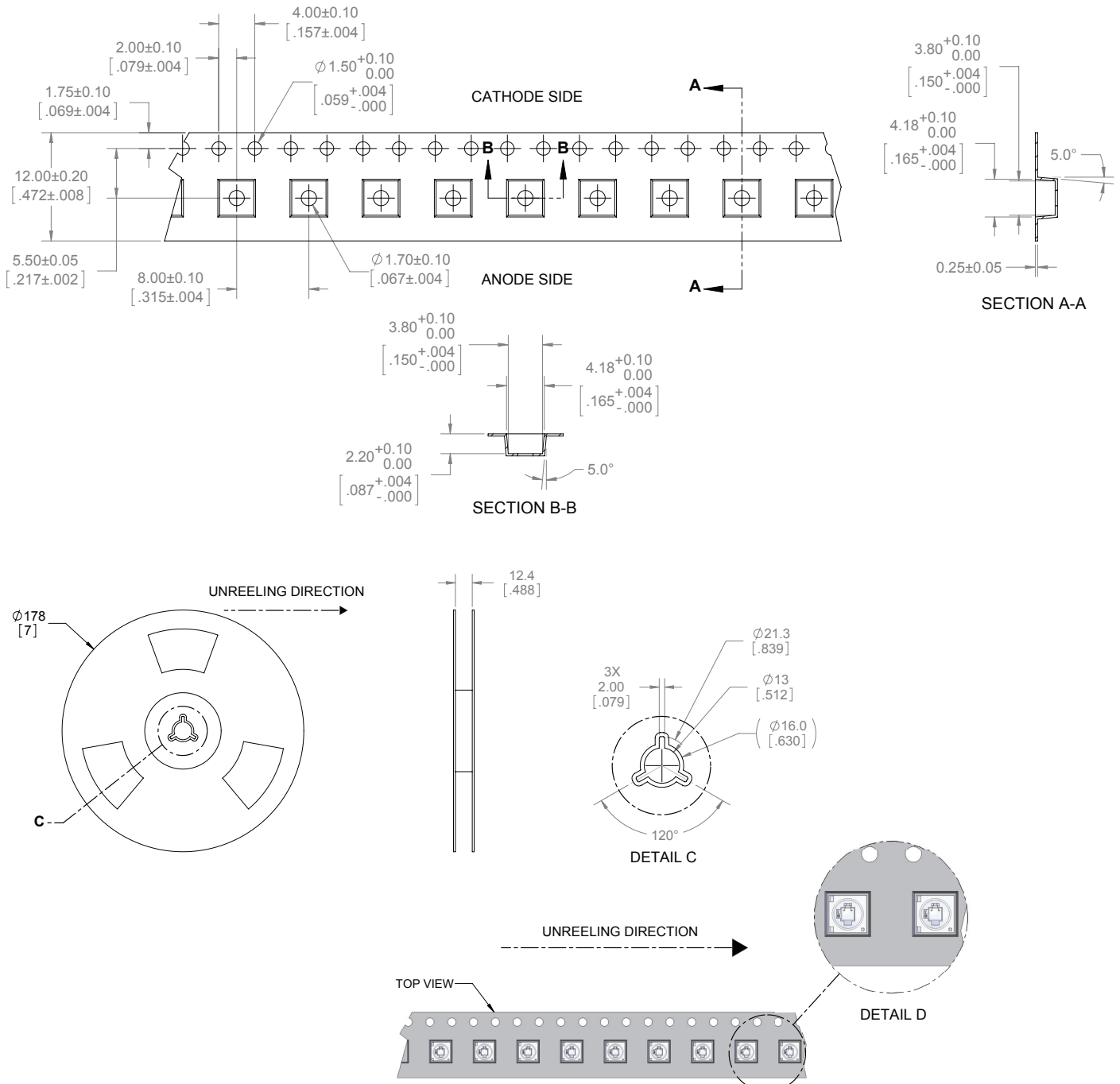

Note:

1. Each reel contains 1,000 units.
2. Leave 304.8 mm [12.00 in] of type empty for lead in (38 empty pockets).
3. Leave 457.2 mm [18.00 in] of type empty for trailer (57 empty pockets).
4. Must comply to EIA-481-C-2003.
5. Final tape and reel packaging must meet the requirements of JEDEC-STD-033, LEVEL 2A.



Shipping Label

Label on Packaging Box

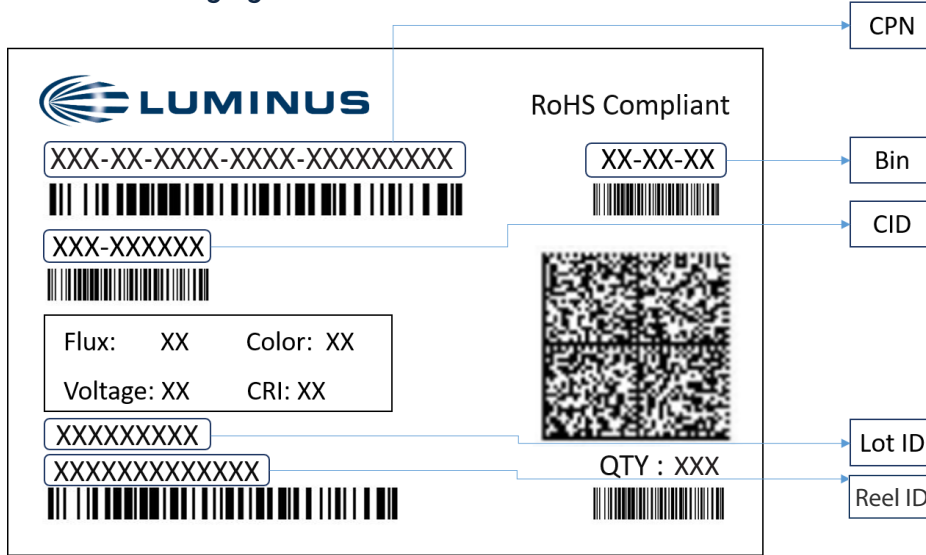

Label Fields:

- CPN:** Luminus ordering part number
- CID:** Customer's part number
- QTY:** Quantity of parts per reel
- Flux:** Bin as defined on page 4
- Voltage:** Bin as defined on page 4
- Color:** Bin as defined on page 5 & 6
- CRI:** NA
- Lot ID & Reel ID:** For Luminus internal use

Label on Reel

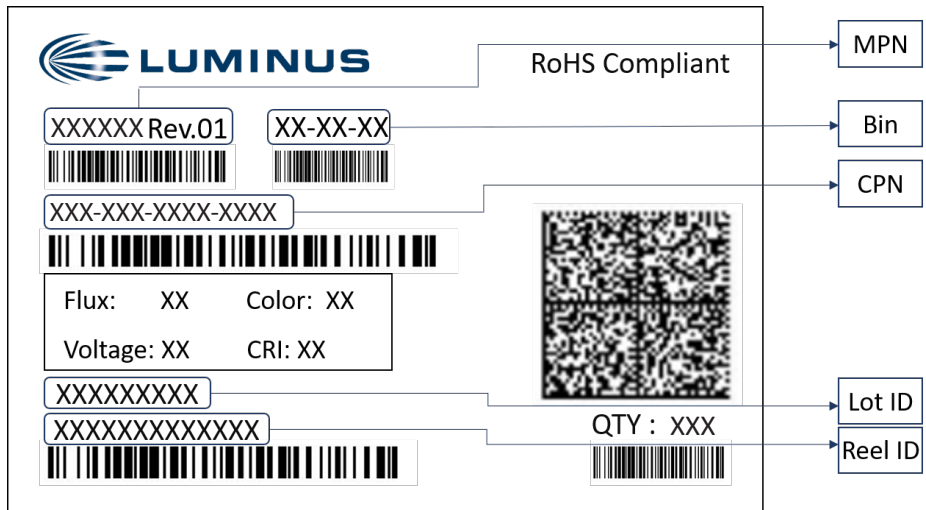

Label Fields:

- CPN:** Luminus ordering part number
- MPN:** For Luminus internal use
- QTY:** Quantity of parts per reel
- Flux:** Bin as defined on page 4
- Voltage:** Bin as defined on page 4
- Color:** Bin as defined on page 5 & 6
- CRI:** NA
- Lot ID & Reel ID:** For Luminus internal use



Packaging

Packaged Reel

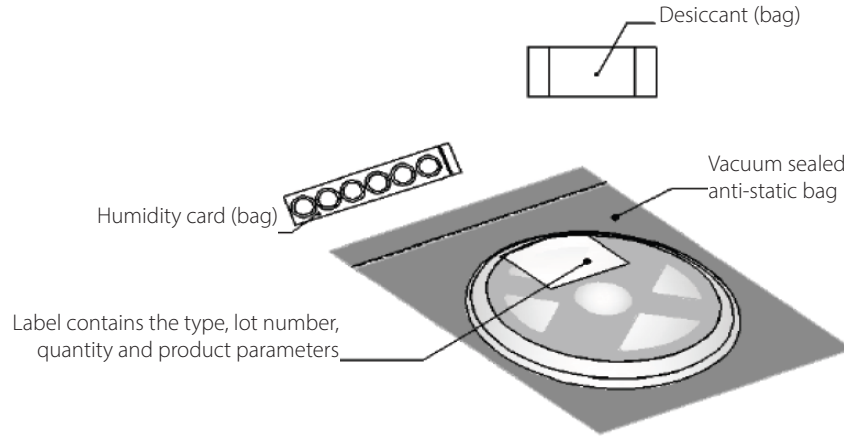

Packaging boxes

Box Size 1 - 5 reels per box
Size: 22.5 x 24.5 x 6.5 cm

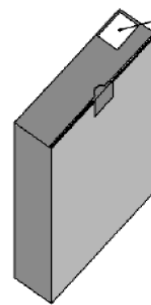
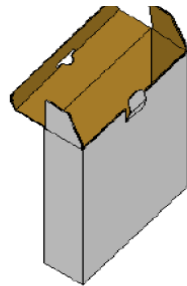

Label contains the type, lot number, quantity and product parameters

*Capacity 5 reels per box

Box Size 2 - 10 reels per box
Size: 22.5 x 24.5 x 13 cm

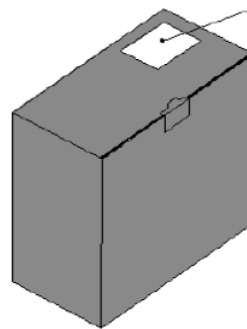
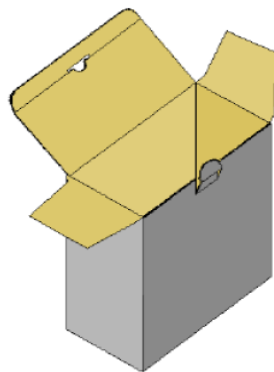

Label contains the type, lot number, quantity and product parameters

*Capacity 10 reels per box

Packing Configuration:

- 1,000 units per reel
- Each reel is enclosed in anti-static bag
- Shipping label is placed on top of each reel
- Multiple labels are attached to the box (one label per reel inside the box)



Notes

Static Electricity

1. The products are sensitive to static electricity, and care should be taken when handling them.
2. Static electricity or surge voltage will damage the LEDs. It is recommended to wear anti-electrostatic gloves or wristband when handling the LEDs.
3. All devices, equipment and machinery must be properly grounded. It is recommended that measures be taken against surge voltage to the equipment that mounts the LEDs.

Reference: [APN-002815](#) Electrical Stress Damage to LEDs and How to Prevent It

Storage

1. Before opening the package

The LEDs should be kept at a temperature lower than 40°C and relative humidity lower than 90%. The LEDs should be used within a year. When storing the LEDs, moisture proof package with absorbent material (silica gel) is recommended.

2. After opening the package

The LEDs should be kept at a temperature lower than 30°C and relative humidity lower than 60%. The LEDs should be soldered within 168 hours (7 days) after opening the moisture proof package.

If unused LEDs remain, they should be stored in moisture proof packages, such as sealed containers with moisture absorbent material (silica gel). It is also recommended to return the unused LEDs to the original moisture proof package and to seal it again.

If the moisture absorbent material (silica gel) vaporizes or passes the expiration date, baking treatment should be performed by using the following conditions : 60°C for 20 hours.

The LED's electrode and lead frame comprise a silver plated copper alloy. The silver surface may be affected by environments. Please avoid conditions which may cause the LEDs to corrode or discolor. The corrosion or discoloration might lower solderability or affect optical characteristics.

Please avoid rapid transition in ambient temperature, especially in high humidity environments where condensation can occur.